

SECTION A-A
SCALE 1 : 1

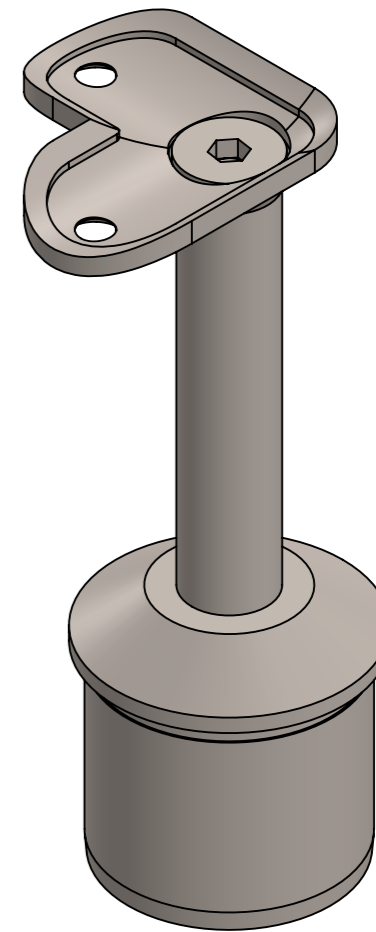
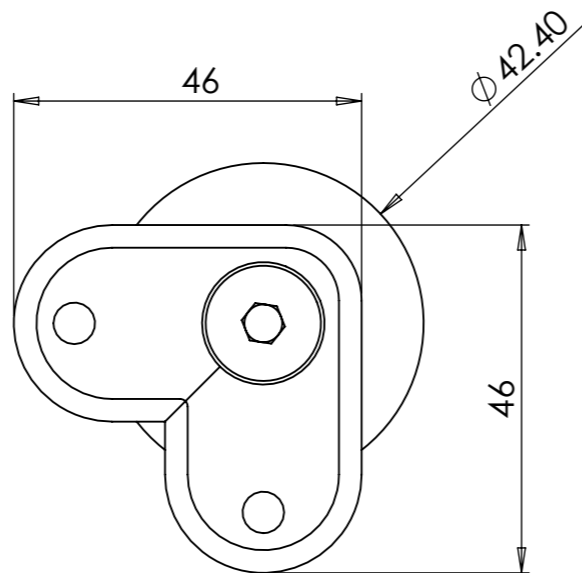

ITEM NO.	PART NUMBER	QTY.
1	M8 X 16 Countersunk Hex Head Bolt	1
2	Part - 1806356C	1
3	65 x Ø14 Stem - Threaded Depth 20mm to Suit M8 Fittings	1
4	Part - 1806357C	1
5	Nylon Washer 20 x 2 With Hole For M8 Fittings	1
6	M8 x 16 Hex Head Bolt	1

NB: Saddle to Suit 42.4mm (316)

Search For Drawings Via Part Number
For More Information See Exploded
View & Bill of Materials Table



Pro-Railing
Tel: 0121 565 8282
Email: prorailing@brundle.com
Web: www.prorailing.co.uk

NOTES: Customer Drawing

DESCRIPTION: Handrail Bracket 42.4mm Fix 90 Degree Fixed Spigot

PART NO: 1806311CC

DWG NO: NA

A3

UNLESS OTHERWISE SPECIFIED ALL DIMENSIONS ARE IN MILLIMETERS			
NAME	DATE	REVISION	C
DRAWN GC	07/10/2015		
REV. BY			

MATERIAL: 316 Stainless Steel

FINISH: Mirror

GRIT SIZE: 320

WEIGHT: 0.21 Kg

SCALE:1:2

DO NOT SCALE DRAWING

SHEET 2 OF 3

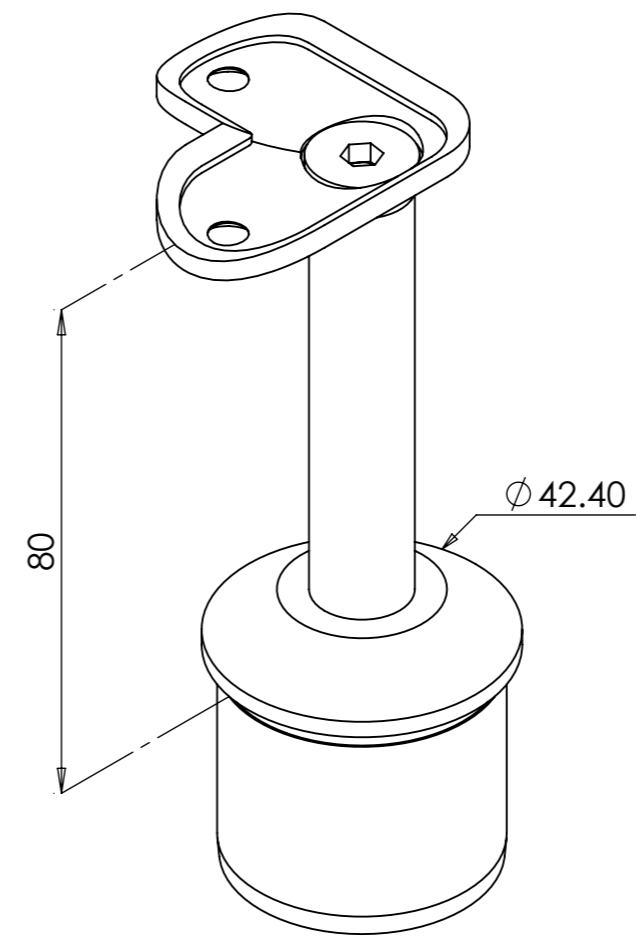
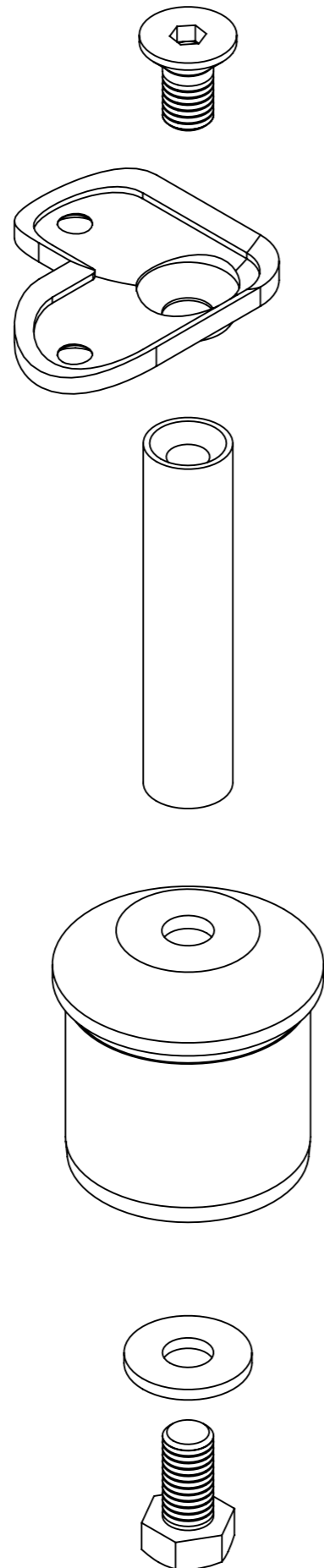

Pro-Railing
 Tel: 0121 565 8282
 Email: prorailing@brundle.com
 Web: www.prorailing.co.uk

NOTES: Isometric View

DESCRIPTION: Handrail Bracket 42.4mm Fix 90 Degree Fixed Spigot

PART NO: 1806311CC

DWG NO: NA

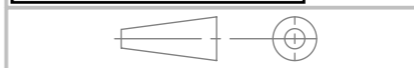

MATERIAL: 316 Stainless Steel

UNLESS OTHERWISE SPECIFIED
 ALL DIMENSIONS ARE IN MILLIMETERS

FINISH: Mirror

GRIT SIZE: 320

WEIGHT: 0.21 Kg

REVISION C

SCALE: 1:2

DO NOT SCALE DRAWING

SHEET 3 OF 3

A3

	NAME	DATE	REVISION
DRAWN	GC	07/10/2015	
REV. BY			